

PACKAGED EQUIPMENT

Total Refrigeration Systems

Easy to buy, install and operate !

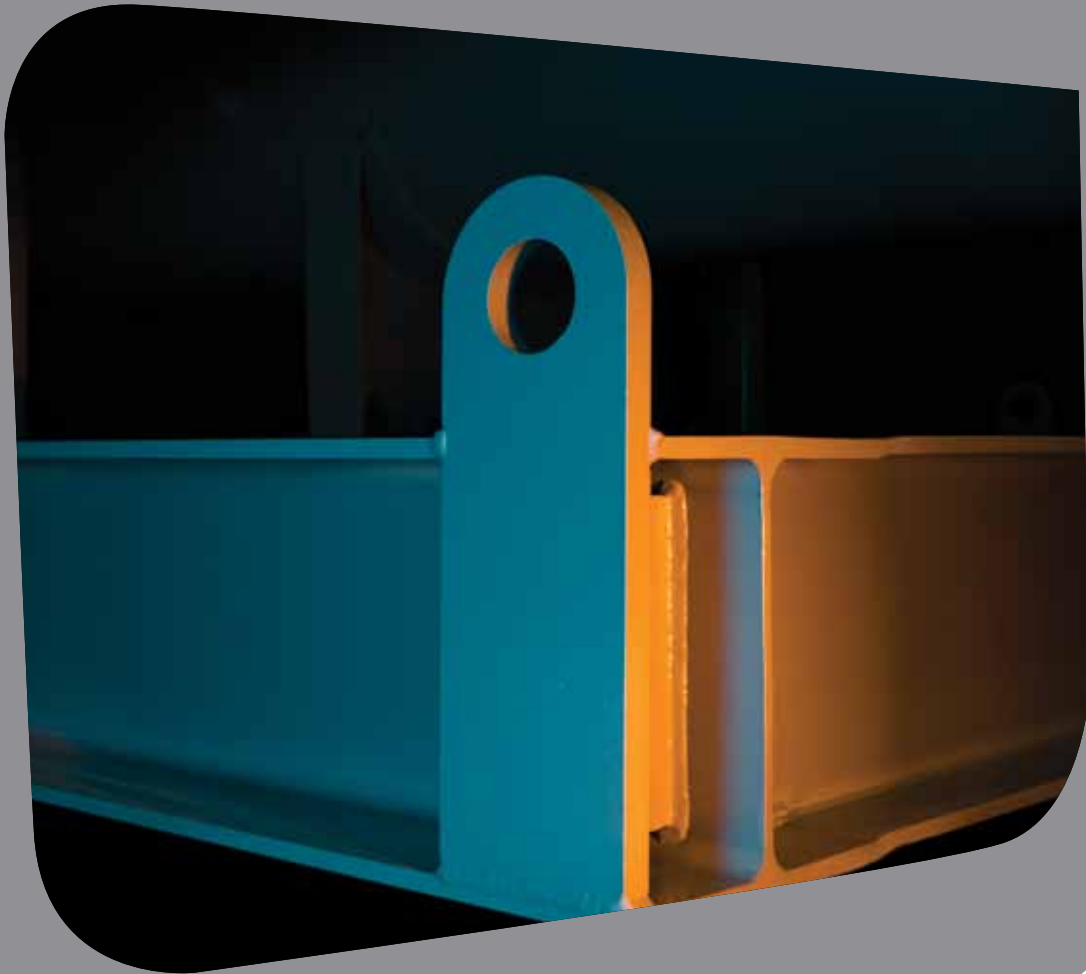

Frick[®]

BY JOHNSON CONTROLS

PowerPac

A completely assembled Industrial Refrigeration Package

Frick® PowerPac™ reduces the need for field labor.

Frick® compressors, heat exchangers, evaporators, and condensers come in a compact package controlled by Frick® Quantum™LX controls and Frick® “turnkey” software.

Your Frick® PowerPac™ puts advanced heat exchanger technology to work for reduced refrigerant usage and maximum operating efficiency.

Reduces the requirement for a Process Safety Management (PSM) program.

Frick® Plus 3 Warranty coverage when installed by a factory-authorized Frick Factor start-up technician.

(Refer to publication E20-100 ADV for details.)



Frick® PowerPac™

- Less jobsite labor means lower cost
- Optimized design means fewer welds
- “Factory Built” controlled environment; site delivered ready to operate
- Simplified electrical hookups
- Process side uses pumped glycol
- Freeze protection from 3-Directional expansion
- Plate and frame heat exchanger means less refrigerant charge

Conventional Site-assembled Chillers

- Multiple vendors mean project management and costs
- More welds equal more cost and time
- Environmental variation during construction
- Expensive on-site electrician for wiring connections
- Process side uses pumped ammonia

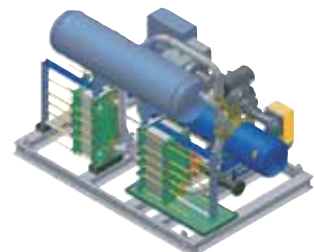
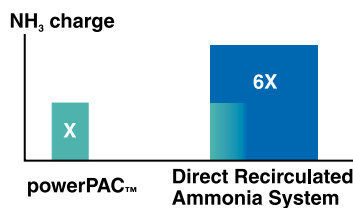
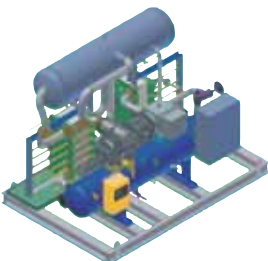



Packaged Ammonia Chiller Units

PowerPac™ units are engineered and manufactured to meet the exacting requirements of the industrial refrigeration market. All components have been designed and arranged to assure reliability, accessibility, and ease of service. Units are completely assembled with all interconnecting refrigerant piping and internal wiring. Optional features include: Dual Oil Filters and Unit-Mounted Solid-State Starter Packages on PowerPac™ 101 and larger. Contact Frick® for details.

Compressor

The Frick® RXF or RWF II rotary screw compressor has been designed utilizing the latest technology to offer the most reliable and energy efficient unit currently available. Compressor casings are designed and tested in accordance with the requirements of ANSI/ASHRAE 15 safety code and are designed for 365 psig working pressure. The rotors are manufactured using the latest asymmetric profiles. The compressor incorporates a complete antifriction bearing design for reduced power consumption, improved efficiency, and reduced maintenance. The bearings provide an L₁₀ life in excess of 100,000 hours at design conditions.

The RXF compressor incorporates a simple mechanism that adjusts the compressor volume ratio during operation to the most efficient of three possible volume ratios, depending on system requirements. The RWF II Compressor includes a patented method of varying the internal volume ratio to match the system pressure ratio. Either compressor reduces the power penalty associated with over/under compression.

CAPACITY CONTROL: Effective capacity control is achieved by use of a slide valve, which provides infinite adjustment from 100% down to 25% of full load for an RXF compressor and down to 10% of full load on an RWF II Compressor.



Vyper™ Variable Speed Drive

Optional **Frick®** Vyper™ VSD provides fast, precise motor speed control to rapidly changing loads while greatly reducing compressor mechanical wear. Vyper™ gradually increases motor speed during start-ups which reduces the mechanical and electrical strain from starting inrush. The liquid-cooled, NEMA 4 rated cabinet provides protection from ammonia vapors while the Quantum™LX control panel provides a user-friendly interface for ease of operation.

Motor

A factory mounted flange motor is close-coupled to the compressor. The compressor/motor assembly requires no field coupling alignment. Standard motors are open drip proof (ODP) and have class B insulation and 1.15 service factor.

Capacity Chart/Specifications*

	Model	PAC 50	PAC 101	PAC 222
	Cooling Cap. (tons)	74	147	338
	Power (bhp)	121	238	489
	Dim's (W x L x H) (in.)	96x112x102	96x170x108	126x214x144
	Weight (lb)	10,890	16,940	34,760
Evaporator	Fluid IN (°F)	22	22	22
	Fluid OUT (°F)	12	12	12
	Water PD (psi)	5.9	6.7	13.5
	Connection Size (in.)	4	4	6
Condenser	Fluid IN (°F)	85	85	85
	Fluid OUT (°F)	92	92	92
	Water PD (psi)	9.7	11.6	14.3
	Connection Size (in.)	4	4	6

* Based on 40% Ethylene Glycol using R-717 Condensing Temp. = 95°F, Evap. Temp. = 5°F

PACKAGED EQUIPMENT



Quantum™LX Control Center

The Quantum™LX control panel is factory mounted, NEMA 4, UL® listed, and completely wired with all the required safety and operating devices. A 10.4" Active Color VGA Graphics Display offers a high contrast, crisp, clear display of compressor information and status. Additional Input/Output can be easily installed in the field for upgrades and changes. Three field-selectable serial communication ports allow you to choose from a combination of RS-422, RS-485, or RS-232 port configurations for both interpanel and external communications. Ethernet communications are also available for direct connection to the internet. Included in the microprocessor is time-proportioning capacity control, first-out annunciation, prealarms, volumizer control, access code protection, lead-lag sequencing, four user-defined capacity control modes, trending, maintenance schedule, and more.

Evaporator/Condenser

Semiwelded plate heat exchangers that have plates constructed of AISI 316 Stainless Steel. Gaskets are a two-piece construction for excellent compatibility with refrigerant and cooling media. Design working pressure is 300 psig. The plate heat exchangers can be disassembled for easy cleaning and capacity modification.

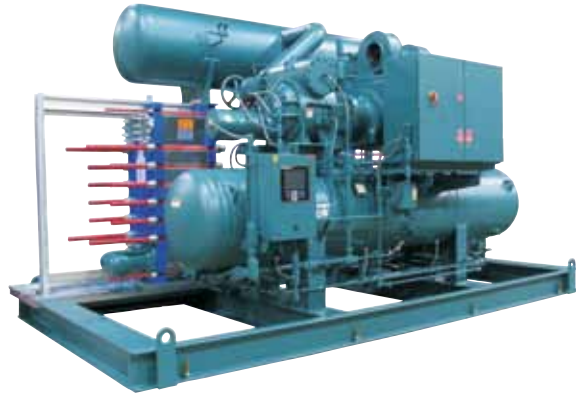

Oil Recovery System

The lubricating oil leaving the compressor unit is automatically recovered from the evaporator and returned to the compressor unit. Oil maintenance is required only at regularly scheduled service intervals.

The PowerPac™ chiller comes complete with the previously described components. The package is dried and pressurized with a nitrogen charge. The initial charge of lubricating oil is provided and shipped loose with the package. Insulation for the vessels and heat exchangers, and charging the package with refrigerant, should be provided by others at the jobsite.



SmartPac

Packaged Ammonia Heat Pumps

A complete packaged solution that reduces water heating costs in your ammonia refrigeration facility

Frick SmartPac™ Heat Pumps

SmartPac™ Heat Pumps capture the heat from your ammonia refrigeration system that is normally rejected to the atmosphere. SmartPac™ then transforms this valuable resource into hot water that can then be utilized throughout your industrial facility.

SmartPac™ enables you to make more efficient use of your ammonia refrigeration system ... bottom line ... lower utility bills and a reduced carbon footprint.

Frick® SmartPac™ – Easy to Install; Easy to Own

Frick screw compressors, heat exchangers, pressure vessels and controls all come together in a compact package ready to install.

Advanced heat exchanger technology increases operating efficiency with a reduced refrigerant charge.

When installed by a Frick Factor, get a 3-year warranty – No worries start saving \$\$ now.

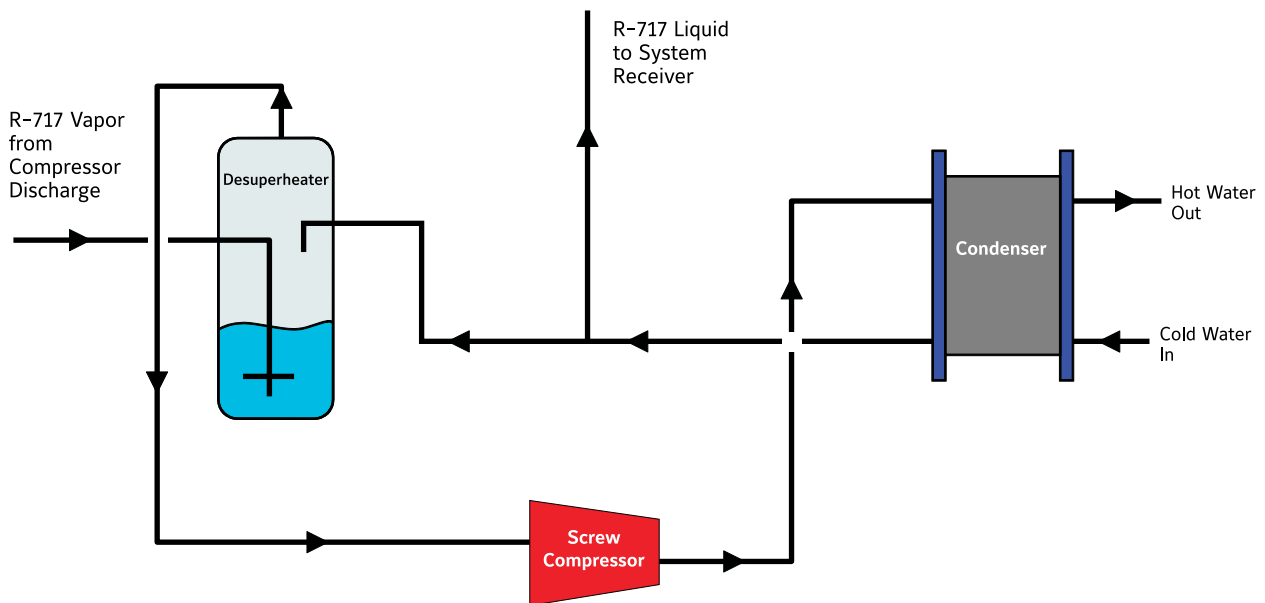

SmartPac™ Applications

- Beef
- Poultry
- Dairy
- Brewery
- Prepared Foods
- Ice Rinks
- District Heating

PACKAGED EQUIPMENT

SmartPac™ Heat Pump

Packaged Ammonia Heat Pump

SmartPac™ heat pumps are designed and manufactured to meet the high quality standards of the industrial refrigeration industry. SmartPac™ is designed to be reliable and accessible. All components are fully assembled, wired and tested on a single base, ready to install.

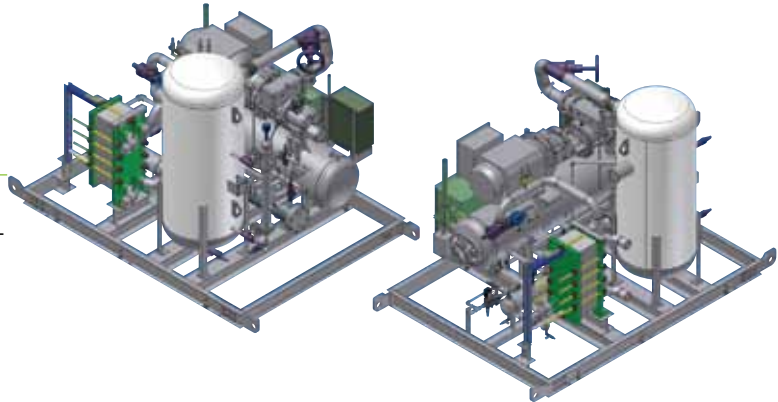

Compressor

Frick® rotary screw compressors are designed to be the most energy efficient and reliable compressors available on the market today. From antifriction roller bearings to onboard computer controls, Frick® compressors utilize the latest technology in both mechanical and electrical design.

Heat Exchanger

Frick® state-of-the-art plate heat exchanger technology for increased efficiency and reduced refrigerant charge. Semi-welded titanium ensures reliability for many years of service.

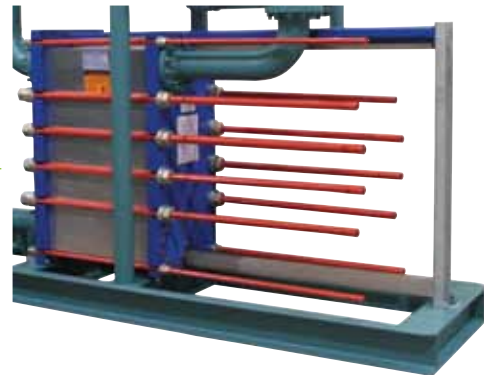

Vessels

ASME and National Board certified Frick® pressure vessels are engineered to exacting standards for safe, reliable operation. Quality and cleanliness, Frick® pressure vessels are the best choice for any industrial refrigeration system.

Controls

The Frick® Quantum™LX control center is the most advanced and versatile industrial controller available. Easy to use and reliable, the Quantum™LX is on the job 24/7 to ensure your equipment is operating safely and efficiently.





A smart, environmentally friendly way to upgrade your facility and reduce your carbon footprint!

SmartPac™ Heat Pump Specifications / Capacity Chart

Model	Water gpm (1)	Heat Source Winter/ Summer (2)	Heating Capacity kBtu/Hr	COP	Power Consumption BHP	Motor Size HP	Shipping Weight lb	Approximate Dimensions		
								L inches	W inches	H inches
SmartPac 24	40	Winter	1,496.9	4.52	129.1	150	12,000	216	132	108
	58	Summer	2,313.9	6.75	134.6					
SmartPac 58	92	Winter	3,730.6	4.83	303.5	335	14,500	240	144	120
	105	Summer	4,313.3	5.61	301.8					
SmartPac 68	110	Winter	4,472.3	4.87	360.2	368	15,500	240	144	120
	125	Summer	5,172.1	5.67	358.2					
SmartPac 85	140	Winter	5,628.6	4.90	450.6	482	16,500	240	156	120
	160	Summer	6,511.2	5.71	448.0					
SmartPac 177	285	Winter	11,479.7	5.20	866.8	900	36,800	300	150	144
	340	Summer	13,873.7	6.31	862.9					

NOTES:

1. Water Flow is based on incoming water at 60°F and hot water leaving at 140°F.
2. Heat source would be the Saturated Condensing condition of the ammonia refrigeration system. Typically this would be in the 65°F to 95°F range.

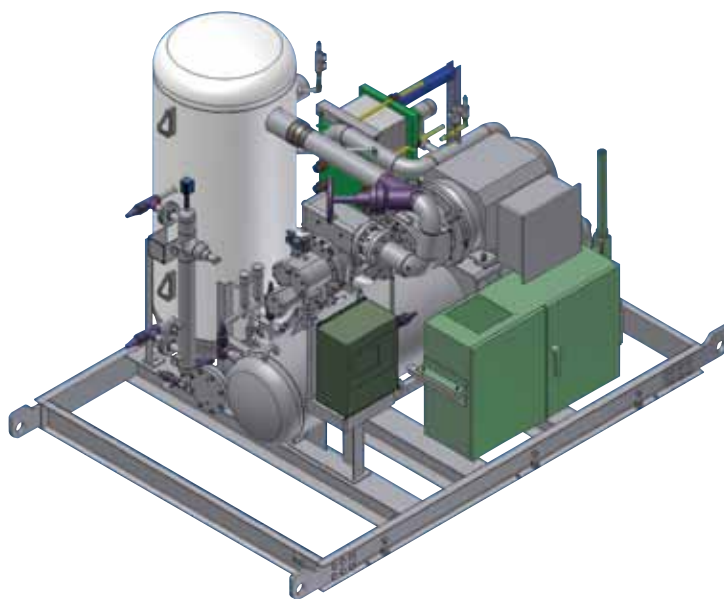

Single Source Industrial Refrigeration Solutions !

Heat Exchangers



Packaged Equipment

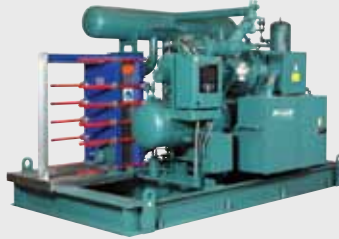

Air Handlers



Vessels



Controls



Evaporators



Compressors



Condensers



Johnson Controls Inc.
 100 CV Avenue • P.O. Box 997
 Waynesboro, PA 17268-0997 U.S.A.
 Tel: 717-762-2121 • Fax: 717-762-8624
www.johnsoncontrols.com/frick

From 170.000-SG1 2010-11
 Subject to change without notice
 Published in U.S.A. • GUI 1M

© 2010 Johnson Controls inc. - All rights reserved
 PRINTED ON CHORUS ART GLOSS TEXT
 CONTAINS 25% POST-CONSUMER WASTE

